

### FEATURES

- 1.180-264V AC/DC input
- 2.Class II driver,without FG,flicker free
- 3.Built in active PFC function,high PF,low THD
- 4.Stanby power consumption <0.5W to turn off dimmable port
- 5.Built in DALI/PUSH/1-10V&10V PWM dimming function
- 6.Constant current mode output with multiple levels selectable by DIP.switch
- 7.Supporting multi-power supplies synchronous dimming connected in parallel
- 8.Cooling by free air convection
- 9.Suitable for indoor LED lighting applications
- 10.5 years warranty

### APPLICATION

- 1.LED indoor lighting
- 2.LED office lighting
- 3.LED architectural lighting
- 4.LED panel lamp lighting

### MODEL CODE

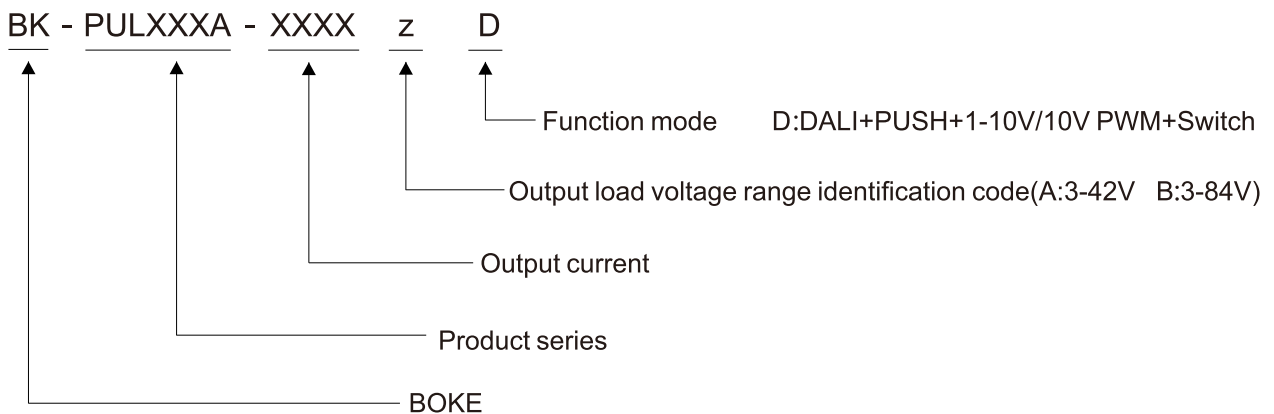

<b>ELECTRICAL SPECIFICATION</b>				
MODEL	BK-PUL030A-0700AD	BK-PUL042A-0700BD	BK-PUL042A-1100AD	BK-PUL060A-2000AD
<b>OUTPUT</b>				
DC current	0.25-0.7A	0.25-0.7A	0.6-1.1A	0.8-2.0A
DC voltage range	3-42V	3-84V	3-42V	3-42V
Rated power	29.4W Max	42W Max	42W Max	61.2W Max
Voltage ripple & noise note.2	≤200mV(Vpp)	≤200mV(Vpp)	≤200mV(Vpp)	≤200mV(Vpp)
Current ripple & noise	≤30mA(RMS)	≤30mA(RMS)	≤30mA(RMS)	≤30mA(RMS)
Constsnt current ADJ. range	DIP S.W	DIP S.W	DIP S.W	DIP S.W
Constant current accuracy	±20mA	±20mA	±30mA	±40mA
Line regulation	±20mA	±20mA	±30mA	±40mA
Load regulation	±20mA	±20mA	±30mA	±40mA
DALI port input current	<1mA(When DIM+is shorted with DIM-)			
1-10V port input current	N/A			
<b>INPUT</b>				
Rated voltage	200-240VAC 200-240VDC			
Input AC voltage range	180-264VAC			
Input DC voltage range	180-264VDC			
Frequency range	47-63Hz			
Power factor	PF>0.95 @ 230VAC/full load,PF>0.90 @ 230VAC/>50% load			
Total harmonic distortion	THD<15% @ 230VAC/full load,THD<20% @ 230VAC/>50% load			
Efficiency (Typ.)	87%	89%	88%	90%
Standby power note.3	<0.5W @ 230Vac	<0.5W @ 230Vac	<0.5W @ 230Vac	<0.5W @ 230Vac
Input current	<0.2A @ 230Vac	<0.3A @ 230Vac	<0.3A @ 230Vac	<0.4A @ 230Vac
Inrush current(Typ.)	Cold start <30A(Twidth=120us measured at 50% Ipeak) @ 230Vac.			
Max. No. of PSUs on 16A circuit breaker	33 units(Type B)/56 units(Type C)	23 units(Type B)/40units(Type C)		16 units(Type B)/28units(Type C)
Turn on delay	<0.5s @ 230Vac			
<b>PROTECTION</b>				
Short circuit	Hiccup,recovers automatically after environment temperature declines			
Max output voltage	50V	100V	50V	50V
Over temperature	Hiccup,recovers automatically after fult condition is removed			
<b>ENVIROHMENT</b>				
Operation temperature	-20-45°C			
Operation humidity	10-90% RH, non-condensing			
Storagr tempera-ture/humidity	-40-80°C,5-95% RH			
IP class	IP20			
Vibration	10~500Hz,5G 12min./1cycle,period for 72min. each along X,Y,Z axes			
Tc	Tc=75°C(Ta=45°C)	Tc=75°C(Ta=45°C)	Tc=75°C(Ta=45°C)	Tc=80°C(Ta=45°C)
MTBF	500000H,MIL-HDBK-217F(25°C)			
LIFETIME	See life curve for details			
<b>EMC</b>				
EMC emisson Note.4	Compliance to EN55015,GB17743,EN61000-3-2 Class C(≥30% load),EN61000-3-3			
EMC immunity	Compliance to EN61000-4-2,3,4,5,6,8,1,EN61547,surge:DM 2KV			
<b>SAFETY</b>				
Safety standards	EN61347-1/2-13,GB19510.1/14,EN62384,IEEE1789			
Dali standards	IEC62386-101,102,207			
Certificate	CE-SUD ENEC CCC SAA RCM			
Withstand voltage	I/P-O/P:3750VAC			
Leakage current	<0.7mA @ 240Vac			
Isolation resis-tance	I/P-O/P:100MΩ/500Vdc/25°C/70% RH			
<b>CONNECTOR</b>				
Environmental protection	RoHS			
Input connection	PCB connector/4PIN/orange+orange+blue+blue/PUL030A PUL042A:0.75-1.5mm <sup>2</sup> /PUL060A:0.75-2.0mm <sup>2</sup>			
Output connection	PCB connector/4PIN/black+green+red+black/0.5-1.5mm <sup>2</sup>			
<b>NOTE</b>	1.All parameter are measured at 230VAC input,rated load and 25°C of ambient temperature. 2.Ripple & Noise are measured at 20MHz of bandwidth by using a 12" twisted pair-wire terminated with a 0.1uF & 47uF paralld capacitor. 3.Stand-by power consumption is measured at dimmable off condition. 4.The power supply is considers as a compent that will be operated in combination with final equipment.Since EMC performance will be affected by the complete installation the final equipment manufactures must re-quality EMC directive on the complete installation again. 5.If this driver used for led lighting, the TC should not higher than TC showed on the driver when the lighting working on the highest rated working tempreture.			

## Electrical characteristics

### BK-PUL030A-0700AD Electrical characteristics(42V/0.7A)

THD vs. Load

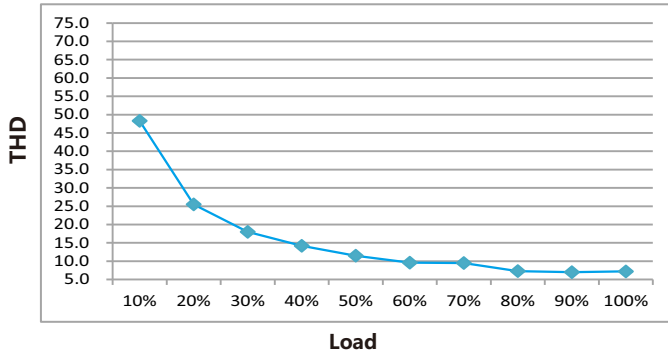

Power factor vs. Load

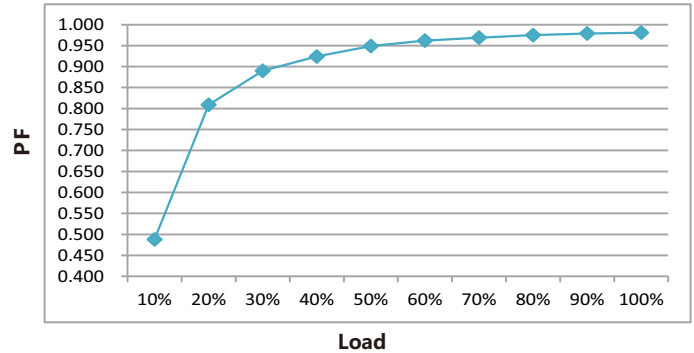

Efficiency vs. Load

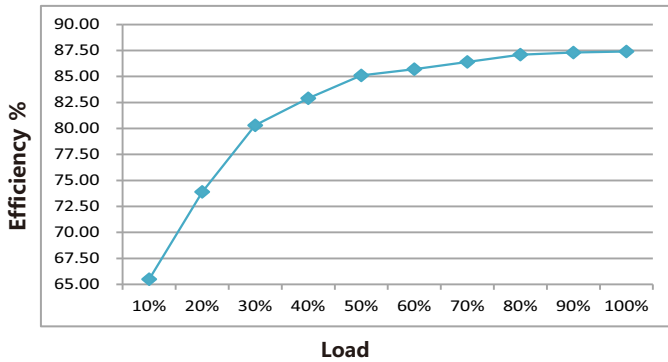

Lifetime vs. case temperature

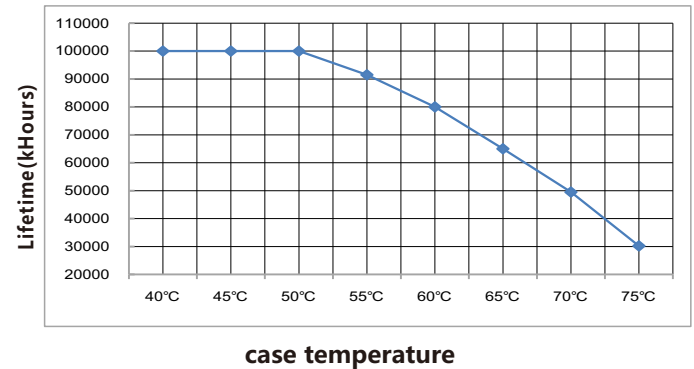

### BK-PUL042A-0700BD Electrical characteristics(84V/0.5A)

THD vs. Load

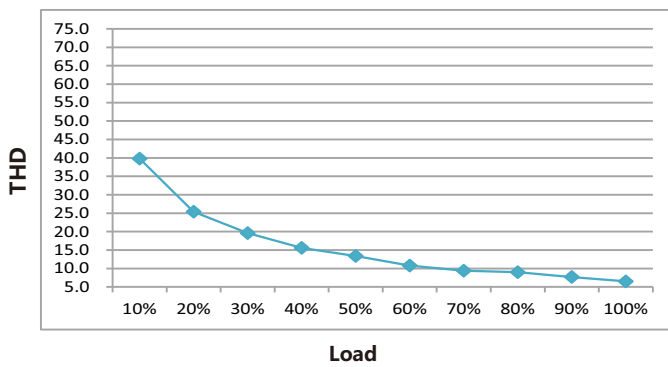

Power factor vs. Load

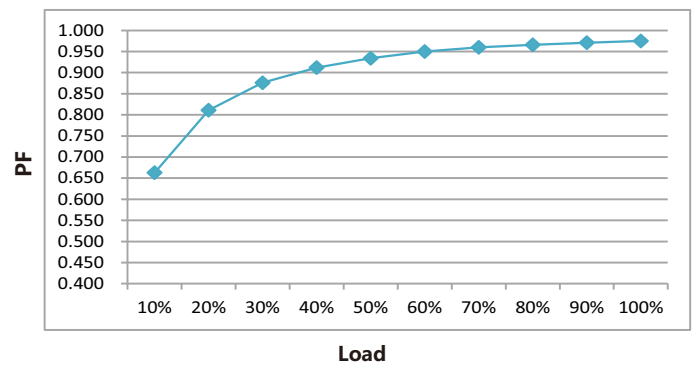

Efficiency vs. Load

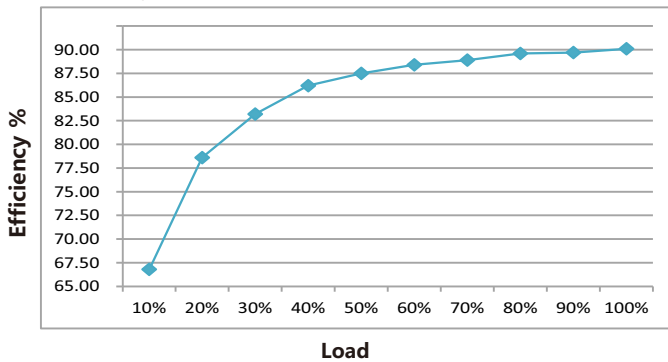

Lifetime vs. case temperature

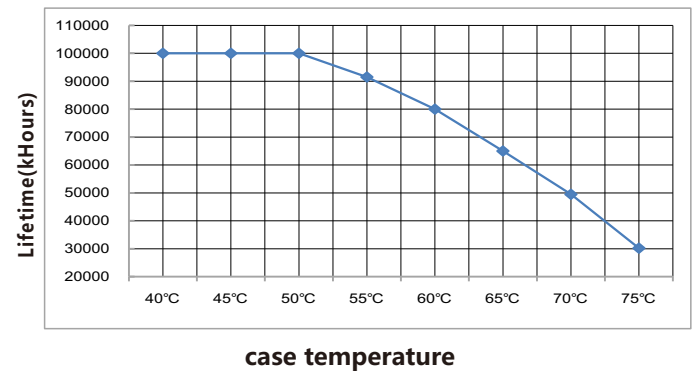

## Electrical characteristics

### BK-PUL042A-1100AD Electrical characteristics(42V/1A)

THD vs. Load

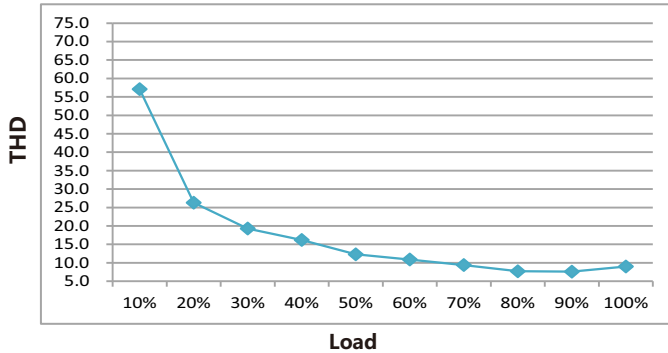

Power factor vs. Load

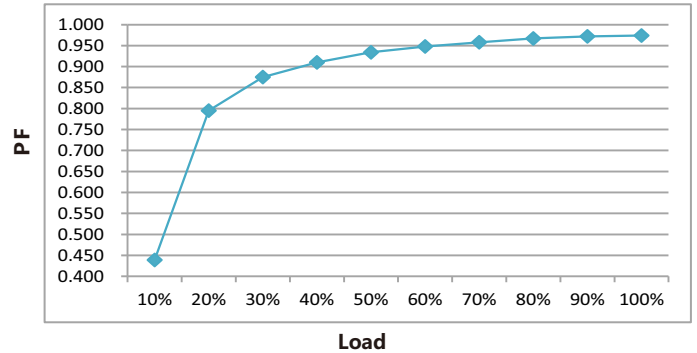

Efficiency vs. Load

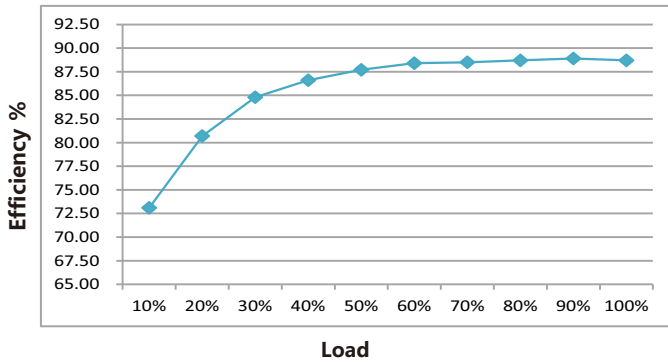

Lifetime vs. case temperature

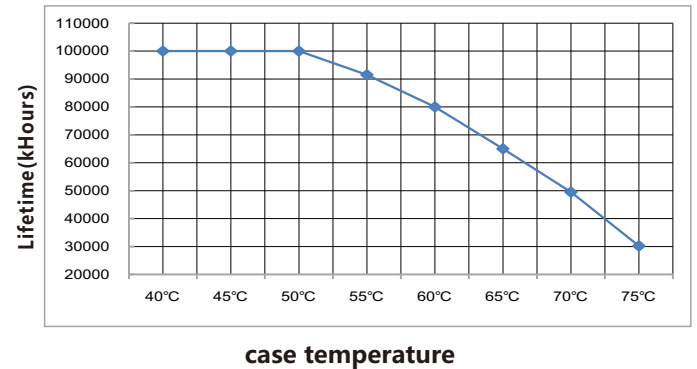

### BK-PUL060A-2000AD Electrical characteristics(42V/1.5A)

THD vs. Load

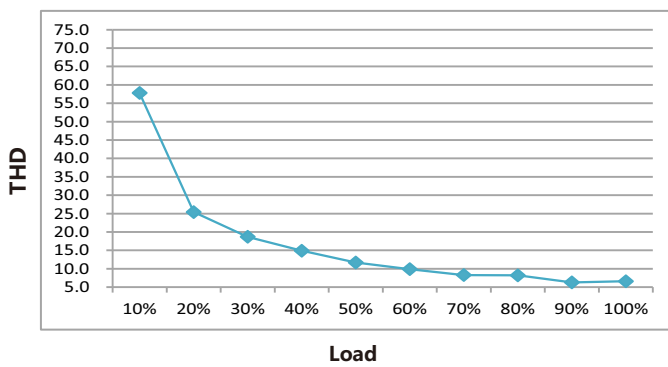

Power factor vs. Load

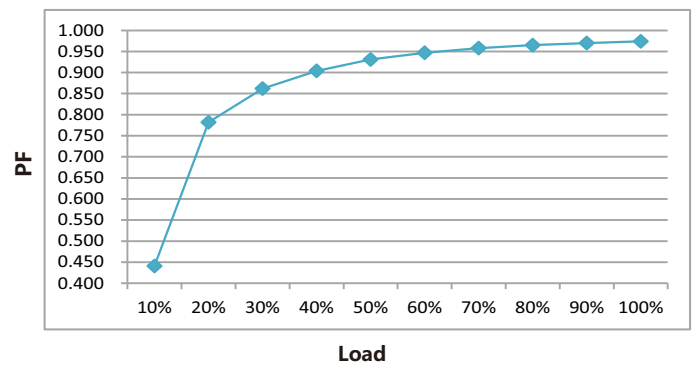

Efficiency vs. Load

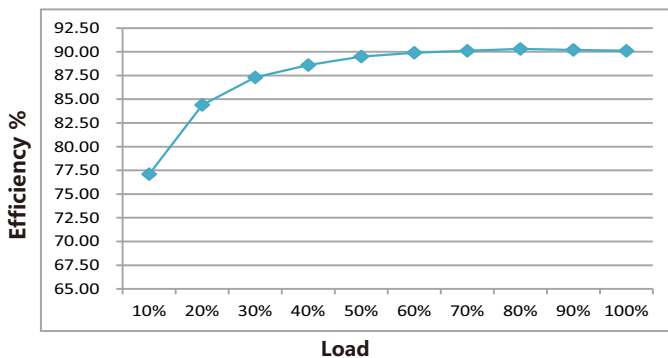

Lifetime vs. case temperature

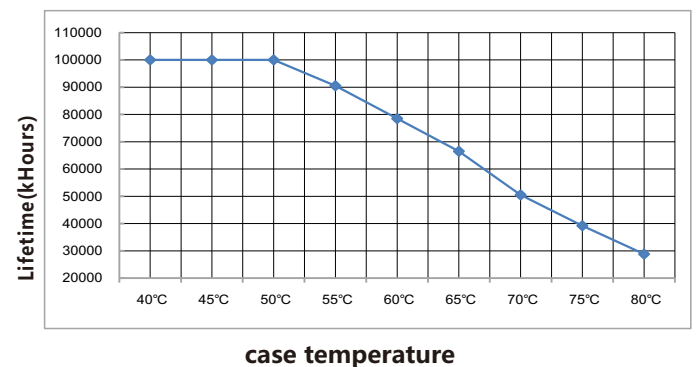

### DIP S.W Select output current table

BK-PUL030A-0700AD

PIN typ.	Irated	Output Voltage	1	2	3	4
12.7W	250mA	42VDC	--	ON	ON	ON
14.9W	300mA	42VDC	ON	--	ON	ON
17.4W	350mA	42VDC	--	--	ON	ON
19.5W	400mA	42VDC	--	ON	--	ON
21.9W	450mA	42VDC	--	--	--	ON
24.3W	500mA	42VDC	ON	ON	ON	--
26.5W	550mA	42VDC	--	--	ON	--
28.9W	600mA	42VDC	--	ON	--	--
31.3W	650mA	42VDC	ON	--	--	--
33.7W	700mA	★ 42VDC	--	--	--	--

BK-PUL042A-0700BD

PIN typ.	Irated	Output Voltage	1	2	3	4
23W	250mA	84VDC	--	ON	ON	ON
28W	300mA	84VDC	ON	--	ON	ON
32W	350mA	84VDC	--	--	ON	ON
37W	400mA	84VDC	--	ON	--	ON
41W	450mA	84VDC	--	--	--	ON
46W	500mA	84VDC	ON	ON	ON	--
46W	550mA	76VDC	--	--	ON	--
46W	600mA	70VDC	--	ON	--	--
46W	650mA	64VDC	ON	--	--	--
47W	700mA	★ 60VDC	--	--	--	--

BK-PUL042A-1100AD

PIN typ.	Irated	Output Voltage	1	2	3	4
29W	600mA	42VDC		ON	ON	ON
34W	700mA	42VDC	ON	--	ON	ON
36W	750mA	42VDC	--	--	ON	ON
39W	800mA	42VDC	--	ON	--	ON
41W	850mA	42VDC	--	--	--	ON
43W	900mA	42VDC	ON	ON	ON	--
46W	950mA	42VDC	--	--	ON	--
48W	1000mA	42VDC	--	ON	--	--
48W	1050mA	40VDC	ON	--	--	--
48W	1100mA	★ 38VDC	--	--	--	--

BK-PUL060A-2000AD

PIN typ.	Irated	Output Voltage	1	2	3	4	5	6
38W	800mA	42VDC	ON	--	ON	--	ON	ON
43W	900mA	42VDC	--	--	--	--	--	ON
47W	1000mA	42VDC	ON	ON	ON	--	ON	--
52W	1100mA	42VDC	--	ON	ON	--	ON	--
54W	1150mA	42VDC	--	--	--	--	ON	--
56W	1200mA	42VDC	--	ON	ON	ON	--	--
59W	1250mA	42VDC	ON	--	ON	ON	--	--
61W	1300mA	42VDC	--	--	ON	ON	--	--
65W	1400mA	42VDC	--	ON	--	ON	--	--
68W	1500mA	40VDC	--	--	--	ON	--	--
69W	1600mA	38VDC	ON	ON	ON	--	--	--
69W	1700mA	36VDC	--	--	ON	--	--	--
69W	1800mA	34VDC	--	ON	--	--	--	--
69W	1900mA	32VDC	ON	--	--	--	--	--
69W	2000mA	★ 30VDC	--	--	--	--	--	--

Remark: ★ this current is factory default.

-- this channel is off.

### Lable

**BOKE Dimmable Constant Current LED Driver**  
**MODEL: BK-PUL030A-0700AD**  
 INPUT: 200-240VAC ~ 50/60Hz 0.2A Max λ:0.95  
 OUTPUT: 50V ~ Max other ratings see below sheet

Do not energize the driver before connecting the LED.  
 Do not connect LED+/- and dimming wires.  
 DIM port is connected to the SELV source.  
 Short circuit DIM port at least 2 sec to reset the driver.

Switching selection sheet

PIN typ.	Irated	Output Voltage	Prated	1	2	3	4
12.7W	250mA	3-42VDC	10.5W	ON	ON	ON	ON
14.9W	300mA	3-42VDC	12.6W	ON	ON	ON	ON
17.4W	350mA	3-42VDC	14.7W	ON	ON	ON	ON
19.5W	400mA	3-42VDC	16.8W	ON	ON	ON	ON
21.9W	450mA	3-42VDC	18.9W	ON	ON	ON	ON
24.3W	500mA	3-42VDC	21.0W	ON	ON	ON	ON
26.5W	550mA	3-42VDC	23.1W	ON	ON	ON	ON
28.9W	600mA	3-42VDC	25.2W	ON	ON	ON	ON
31.3W	650mA	3-42VDC	27.3W	ON	ON	ON	ON
33.7W	700mA	3-42VDC	29.4W	ON	ON	ON	ON

Before use, always check dipswitch settings!

tc = 75°C  
 ta = 45°C

MADE IN CHINA  
 For LED Modules use only

DA ■  
 DA ■  
 ACN ■  
 ACL ■

**BOKE Dimmable Constant Current LED Driver**  
**MODEL: BK-PUL042A-0700BD**  
 INPUT: 200-240VAC ~ 50/60Hz 0.3A Max λ:0.95  
 OUTPUT: 100V ~ Max other ratings see below sheet

Do not energize the driver before connecting the LED.  
 Do not connect LED+/- and dimming wires.  
 DIM port is connected to the SELV source.  
 Short circuit DIM port at least 2 sec to reset the driver.

Switching selection sheet

PIN typ.	Irated	Output Voltage	Prated	1	2	3	4
24W	250mA	3-84VDC	21W	ON	ON	ON	ON
28W	300mA	3-84VDC	25.2W	ON	ON	ON	ON
33W	350mA	3-84VDC	29.4W	ON	ON	ON	ON
38W	400mA	3-84VDC	33.6W	ON	ON	ON	ON
42W	450mA	3-84VDC	37.8W	ON	ON	ON	ON
47W	500mA	3-84VDC	42W	ON	ON	ON	ON
47W	550mA	3-78VDC	41.8W	ON	ON	ON	ON
47W	600mA	3-70VDC	42W	ON	ON	ON	ON
47W	650mA	3-64VDC	41.6W	ON	ON	ON	ON
48W	700mA	3-60VDC	42W	ON	ON	ON	ON

Before use, always check dipswitch settings!

tc = 75°C  
 ta = 45°C

MADE IN CHINA  
 For LED Modules use only

DA ■  
 DA ■  
 ACN ■  
 ACL ■

**BOKE Dimmable Constant Current LED Driver**  
**MODEL: BK-PUL042A-1100AD**  
 INPUT: 200-240VAC ~ 50/60Hz 0.3A Max λ:0.95  
 OUTPUT: 50V ~ Max other ratings see below sheet

Do not energize the driver before connecting the LED.  
 Do not connect LED+/- and dimming wires.  
 DIM port is connected to the SELV source.  
 Short circuit DIM port at least 2 sec to reset the driver.

Switching selection sheet

PIN typ.	Irated	Output Voltage	Prated	1	2	3	4
29W	600mA	3-42VDC	25.2W	ON	ON	ON	ON
34W	700mA	3-42VDC	29.4W	ON	ON	ON	ON
36W	750mA	3-42VDC	31.5W	ON	ON	ON	ON
39W	800mA	3-42VDC	33.6W	ON	ON	ON	ON
41W	850mA	3-42VDC	35.7W	ON	ON	ON	ON
43W	900mA	3-42VDC	37.8W	ON	ON	ON	ON
46W	950mA	3-42VDC	39.9W	ON	ON	ON	ON
48W	1000mA	3-42VDC	42W	ON	ON	ON	ON
48W	1050mA	3-40VDC	42W	ON	ON	ON	ON
48W	1100mA	3-38VDC	41.8W	ON	ON	ON	ON

Before use, always check dipswitch settings!

tc = 75°C  
 ta = 45°C

MADE IN CHINA  
 For LED Modules use only

DA ■  
 DA ■  
 ACN ■  
 ACL ■

**BOKE Dimmable Constant Current LED Driver**  
**MODEL: BK-PUL060A-2000AD**  
 INPUT: 200-240V ~ 50/60Hz 0.4A Max λ:0.95  
 OUTPUT: 50V ~ Max other ratings see below sheet

Do not energize the driver before connecting the LED.  
 Do not connect LED+/- and dimming wires.  
 DIM port is connected to the SELV source.  
 Short circuit DIM port at least 2 sec to reset the driver.

Switching selection sheet

PIN typ.	Irated	Output Voltage	Prated	1	2	3	4	5	6
38W	800mA	3-42VDC	33.6W	ON	ON	ON	ON	ON	ON
43W	900mA	3-42VDC	37.8W	ON	ON	ON	ON	ON	ON
47W	1000mA	3-42VDC	42W	ON	ON	ON	ON	ON	ON
52W	1100mA	3-42VDC	46.2W	ON	ON	ON	ON	ON	ON
54W	1150mA	3-42VDC	48.3W	ON	ON	ON	ON	ON	ON
56W	1200mA	3-42VDC	50.4W	ON	ON	ON	ON	ON	ON
59W	1250mA	3-42VDC	52.5W	ON	ON	ON	ON	ON	ON
61W	1300mA	3-42VDC	54.6W	ON	ON	ON	ON	ON	ON
65W	1400mA	3-42VDC	58.8W	ON	ON	ON	ON	ON	ON
68W	1500mA	3-40VDC	60W	ON	ON	ON	ON	ON	ON
69W	1600mA	3-38VDC	60.8W	ON	ON	ON	ON	ON	ON
69W	1700mA	3-36VDC	61.2W	ON	ON	ON	ON	ON	ON
69W	1800mA	3-34VDC	61.2W	ON	ON	ON	ON	ON	ON
69W	1900mA	3-32VDC	60.8W	ON	ON	ON	ON	ON	ON
69W	2000mA	3-30VDC	60W	ON	ON	ON	ON	ON	ON

Before use, always check dipswitch settings!

tc = 80°C  
 ta = 45°C

MADE IN CHINA  
 For LED Modules use only

DA ■  
 DA ■  
 ACN ■  
 ACL ■

## 1-10VDC/10VPWM dimming

### Wiring diagram

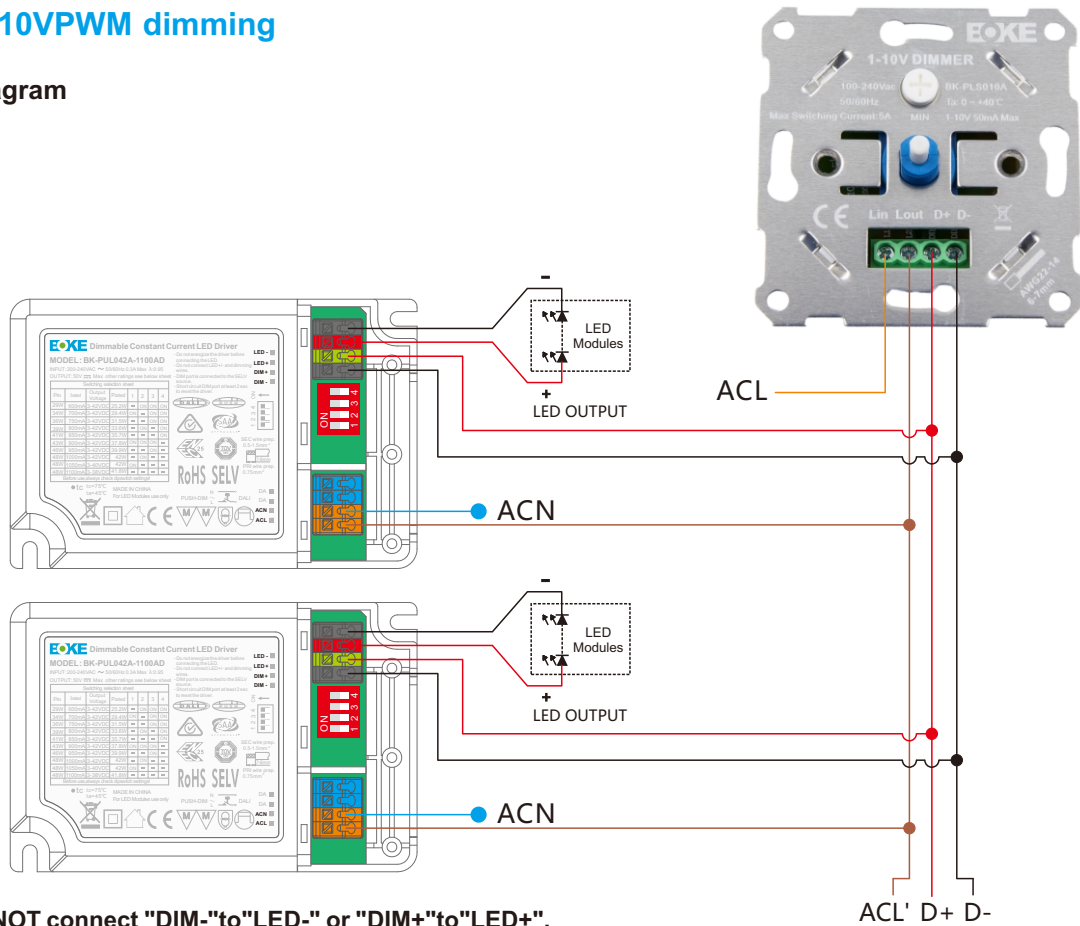

Please DO NOT connect "DIM-" to "LED-" or "DIM+" to "LED+".

### Note

- Dimming interface characteristics: 0.9V and below are closed, 1V is the darkest, 10V is the brightest, 1-10V is the dimming range.
- The dimming interface distinguishes between positive and negative, DIM+ is positive, DIM- is negative, please do not reverse.
- Dimming interface does not support voltage access higher than 20V, otherwise it will cause damage to the internal components.
- When the dimming interface is open, the driver outputs the maximum current. When the interface is short-circuited, the current output is closed.
- When multiple synchronous dimming is required, the positive poles of the dimming interface of each driver are connected together, and the negative poles are connected together.
- Support passive dimmer or isolated active dimmer dimming, does not support non-isolated active dimmer dimming.
- In general, it is recommended that the number of mounted drives does not exceed 25pcs, and the wiring length does not exceed 100m.
- It is recommended that the dimming wires should not be lower than the 18AWG wire or 0.75mm<sup>2</sup> wire.
- Do not put the dimming wires with high voltage or interference sources. If it is unavoidable, please use the shielded wires.
- It is recommended to conduct sample test first and confirm the dimming effect before bulk purchase.
- If you need a drive with 0-10V dimming characteristics, please contact BOKE.

### Dimming graph

Output current vs. Dimming Voltage(Typical)

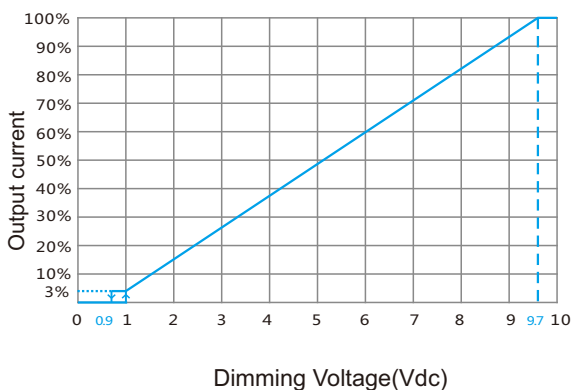

Output current 10V PWM Duty Cycle(Typical)

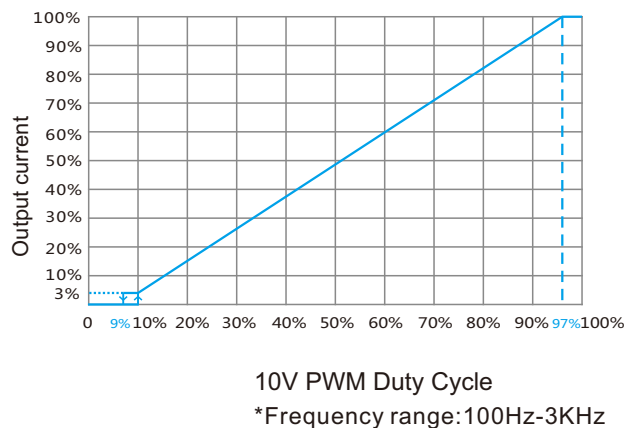

## PUSH dimming

### Wiring diagram

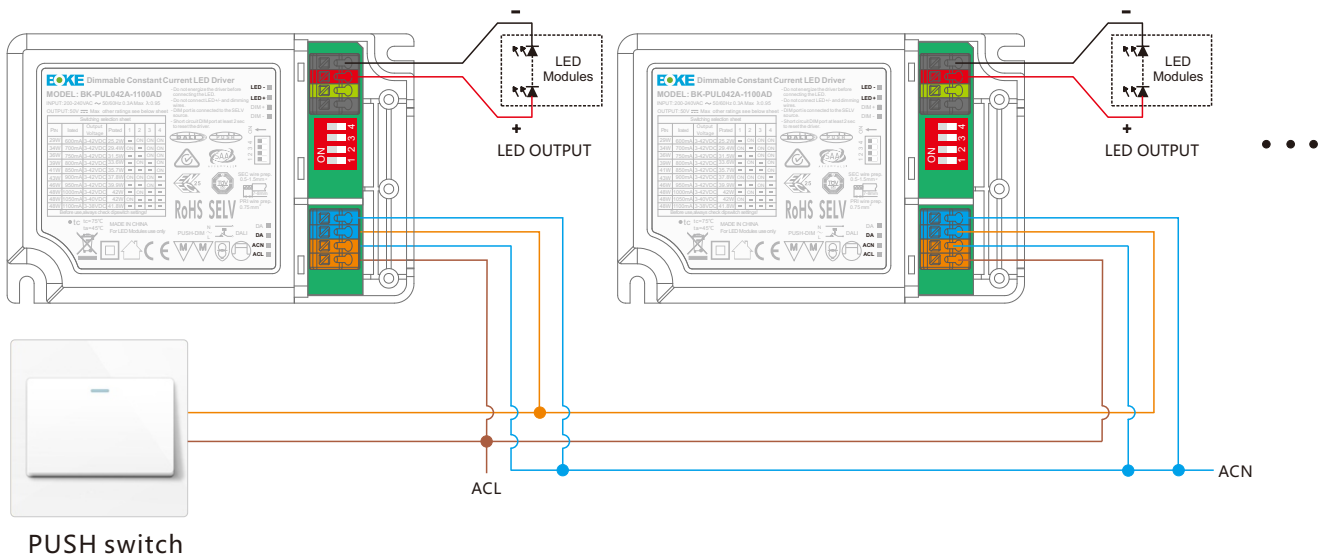

### Note

Turn on or turn off: short press push switch for 0.2-1s.

Dimming: long press push switch for 1-5s.

Power on status: after power on, the light state will be the same as the last lighting on state.

If the light is on before power off, the light will be on after power on again, brightness will be the same as the last lighting on brightness.

If the light is off before power off, the light will be off after power on again, short press the push button, then the light will be on, brightness will be the same as last lighting on brightness.

In general, it is recommended that the number of mounted drives does not exceed 25pcs, and the wiring length does not exceed 100m.

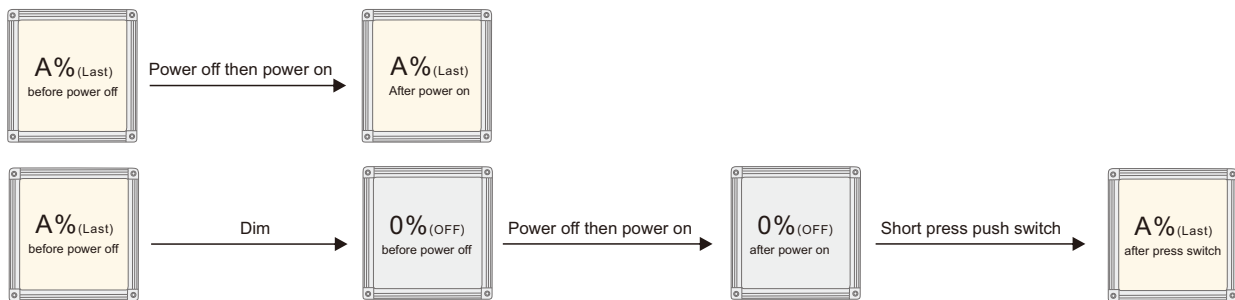

### Multiple lights synchronize control operation

Step 1: long press the PUSH switch, confirm each light is on.

Step 2: short press the PUSH switch, confirm each light is off.

Step 3: long press the PUSH switch, confirm each light is from darkest to brightest and all the lights are synchronous .

## DALI dimming

### Wiring diagram

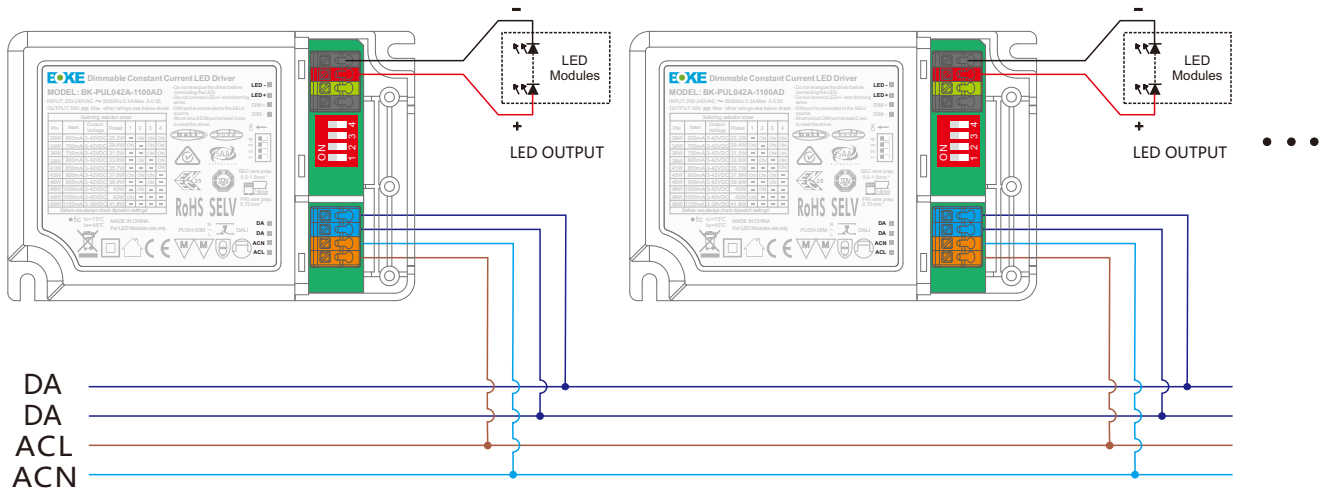

### Note

- Standard DALI control line voltage range:9.5 V to 22.5 V,type 16V.
- The two DALI control lines are polarity-reversible.
- Max. 64 DALI drivers per DALI control line.
- The maximum Distance length of the DALI control line is 300m at 2 x1.5mm<sup>2</sup>.
- DALI bus can be wired together with any mains voltage cables, but separate wiring is recommended.

Please refer to the table below

Cable size	Distance
2×0.50mm <sup>2</sup>	max.100m
2×0.75mm <sup>2</sup>	max.150m
2×1.00mm <sup>2</sup>	max.200m
≥2×1.50mm <sup>2</sup>	max.300m

## Hot plug-in protection function

In the following two cases,the LED driver will automatically turn off the output to protect the LED

- 1.When the driver is powered on first and the LED is connected later.
- 2.When the driver is powered on,disconnected and connected again.

### The LED can be activated in two ways

- 1.Through the AC input port:disconnect the AC of the drive and power it again.
- 2.Through dimming interface

DALI:send“OFF”command first,then send “MAX”command.

PUSH:short press PUSH switch two times,then long press PUSH switch.

1-10V:surn the dimmer to the off position and then turn to the on position.



### Mechanical Specification

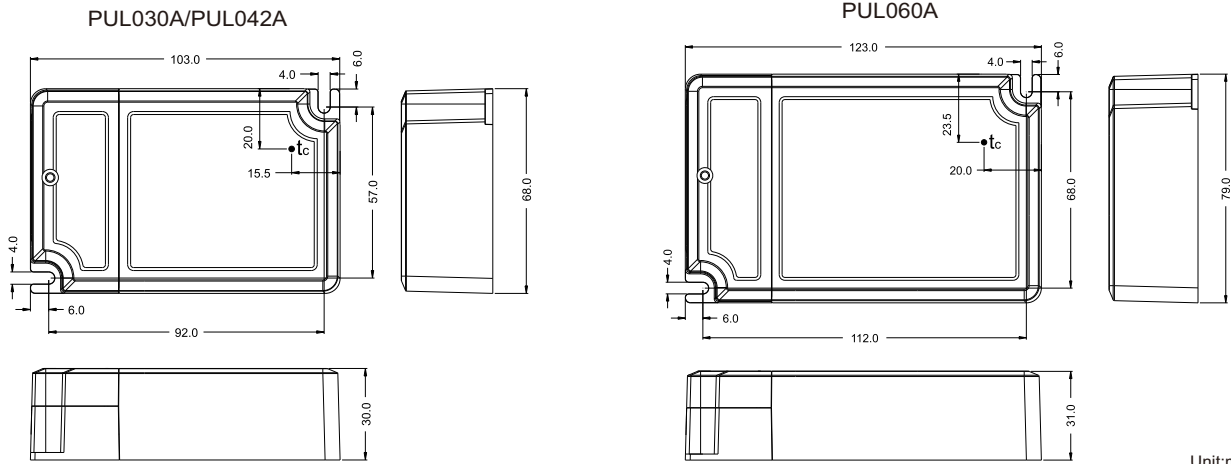

Unit:mm

### Product package

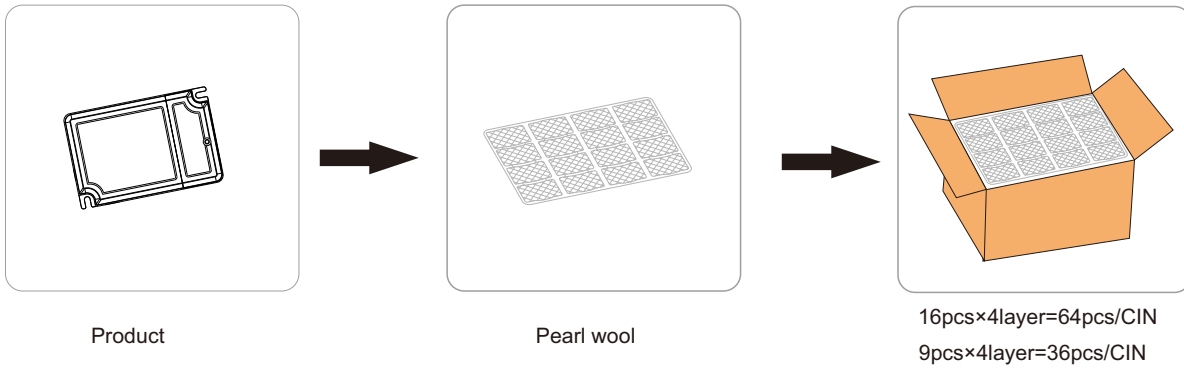

Product	Product size	Weight	Carton size	N.W	G.W	Pearl wool size	Flat card size	Packing
PUL030A	L103*W68*H30mm	140g	L490*W340*H165mm	8.96KG	10. 8KG	L480*W330*H40mm	L480*W330mm	64pcs
PUL042A	L103*W68*H30mm	168g	L490*W340*H165mm	10.8KG	12.1KG	L480*W330*H40mm	L480*W330mm	64pcs
PUL060A	L123*W79*H31mm	248g	L450*W350*H180mm	9. 00KG	11.00KG	L435*W345*H40mm	L435*W335mm	36pcs

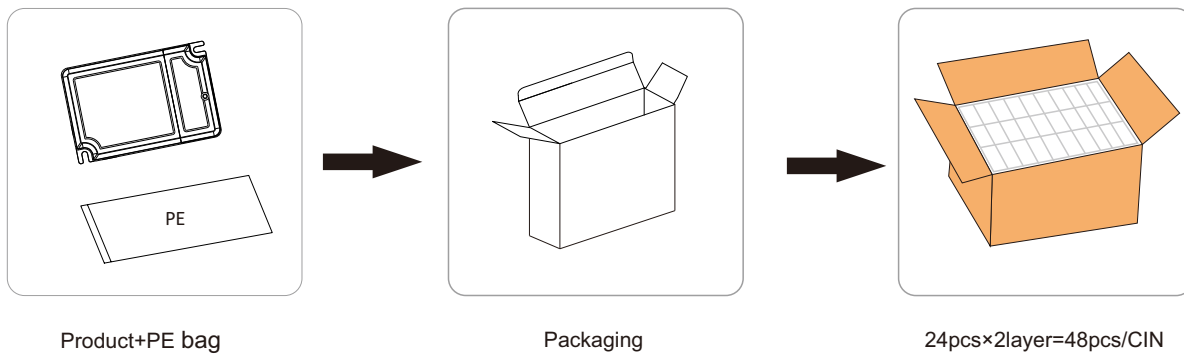

Product	Product size	Weight	Carton size	N.W	G.W	Packaging size	PE bag size	Packing
PUL030A	L103*W68*H30mm	140g	L415*W330*H190mm	6.80KG	9.80KG	L130*W38*H85mm	L250*W150mm	48pcs
PUL042A	L103*W68*H30mm	168g	L415*W330*H190mm	8.10KG	11.2KG	L130*W38*H85mm	L250*W150mm	48pcs
PUL060A	L123*W79*H31mm	248g	L415*W330*H190mm	11.9KG	14.5KG	L130*W38*H85mm	L250*W150mm	48pcs